



## 55" HIGH BRIGHTNESS 7000 NIT LCD WITH NARROW BEZEL

The DS552LT7 is a 55 inch ultra-high bright professional LCD with IPS technology. With a brightness rating of 7000 nits, this display features an LED back light for incredible, high contrast picture quality and low power consumption.

The DS552LT7 features a 10.9 mm bezel, perfect for video wall applications in bright environments.

The display features an integrated Android™ based media player with WiFi offering users a complete media platform, allowing playback of local files and USB/SD card media.



SUNLIGHT  
VIEWABLE



NARROW  
BEZEL



ANDROID  
OS



POLARIZED  
LENSES OK



PORTRAIT &  
LANDSCAPE

## APPLICATIONS

- **STORE FRONT WINDOWS**
- **TRANSPORTATION**
- **FINANCIAL INSTITUTIONS**
- **OUTDOOR ENCLOSURES**
- **DIGITAL ADVERTISING**

# SPECIFICATIONS

PANEL	LCD Panel Type	54.64 inches LCD
	Native Resolution	1920 x 1080
	Backlight	LED
	Brightness	7000 nit
	Default Color Temperature	D65 (6500 K)
	Contrast Ratio	3,000:1
	Color Depth	8 bit
	Response Time	9 ms (typ)
	Viewing Angle	178° / 178°
	Light Life Time	100,000 hrs (typ.)
	Blackening Defect Free	Up to 110°C (230°F)
	Panel Surface	AR 1.5%, 2H, QWP
POWER	Power Supply	Internal
	Rated Voltage	100 V ~ 240 V, 50 Hz / 60 Hz
	Power On Mode	275 W (typ), 400 W (max) (TBC)
MECHANICAL	Bezel Width (T/B/L/R)	Even bezel 10.9 mm
	Cabinet Color	Black
	Monitor Dimension (LxHxD)	1239.4 x 710.0 x 87.7 mm [48.8 x 28.0 x 3.5"]
	Monitor Weight (set/package)	29.5 kg / 34.5 kg [65.0 lb / 76.1 lb] (TBC)
	VESA Mounting (dimension)	400 x 400 mm
	Orientation	Portrait / Landscape
USER INTERFACE	Language	English
	Proof of Image Retention	Yes
	Dimming Control (DCR)	Yes
	On/Off Scheduling	Yes
	Ambient Light Sensor	Yes
	External Control	RS-232 (In), RJ45
	Internal Temperature Sensor	Yes
I/O PORTS	HDMI 2.0	In (x1)
	DisplayPort	In (x1)
	DVI-D	In (x1), Out (x1)
	RS-232	In (x1), Out (x1)
	RJ-45	(x1)
	Audio	In (x1), Out (x1)
	USB 2.0	In (x1), Service Port (x1)
	SD Slot	(x1)
	Mini USB	In (x1) (optional ESK only)
ENVIRONMENT	Operating Temperature	0°C ~ 45°C (32°F ~ 113°F)
	Storage Temperature	-20°C ~ 60°C (-4°F ~ 140°F)
	Humidity	10% ~ 80% RH Non-condensing
ACCESSORIES	Included	Power Cable, Remote Controller (with batteries), QSG
CERTIFICATION	CE / FCC / ROHS	

# DIMENSIONS

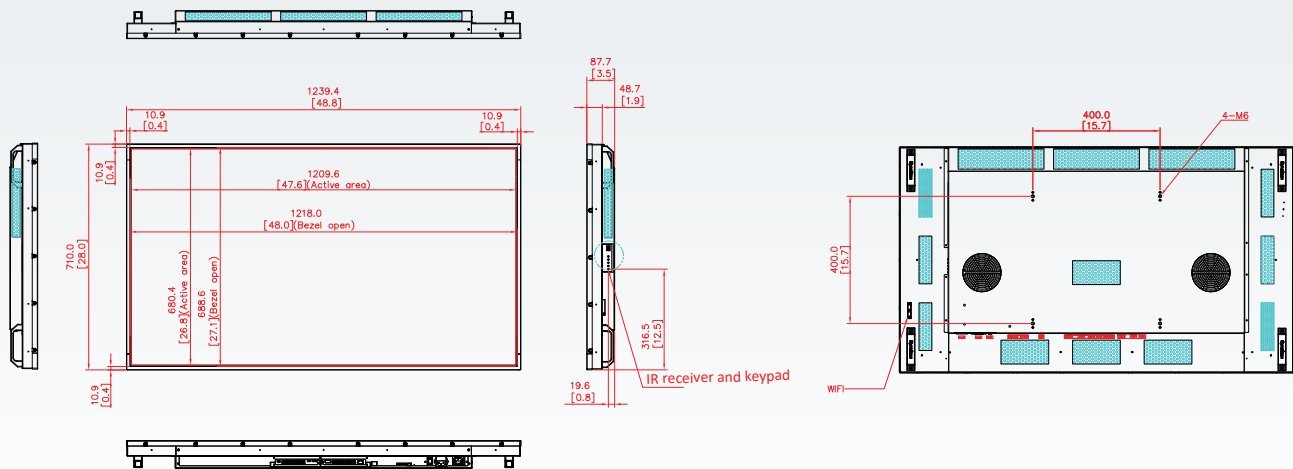

# INTERFACE

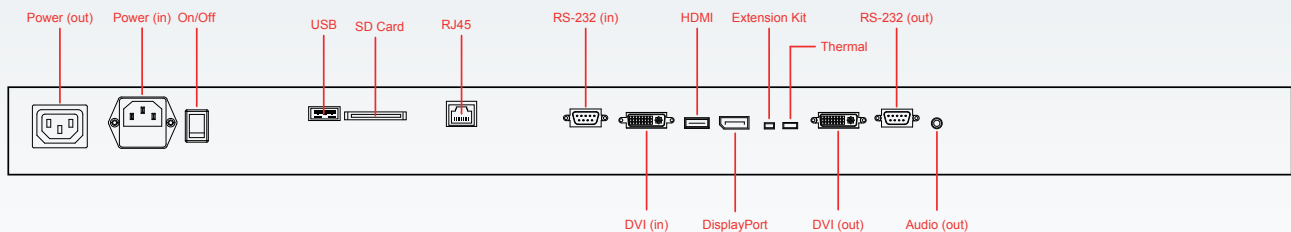

# INTERNAL PLAYER

INTERNAL PLAYER	Operating System	Android 4.4.2
	Processor	ARM Cortex-A9 1.6 GHz, Quad-Core CPU
	On Chip Cache Memory	L2: 512KB
	Clock Speed	1.6 GHz
	Main Memory Interface	1GB DDR3/3L (1600MHz)
	Graphics	600M ARM Mali400MP4, 2D/3D graphic engine, support OpenGL ES1.1/2.0, Open VG1.1
	Storage (FDM)	8GB NAND Flash (2 GB occupied by OS, 6GB available depending on total capacity)
	Multimedia	H.264 encoder/decoder, MPEG-1/2/4, H.263, H.264 MVC, AVS, VC-1, VP8/6, RV



5500 nit model shown

# FEATURES



### Sunlight Viewable Image

With a brightness rating of 7000 nits, the display can easily be viewed in direct sunlight applications.



### Blackening Defect-free

High Tni panel prevents blackening when exposed to high temperatures.



### Viewable with Polarized Lenses

Utilizes quarter-wave plate technology to allow for viewing with polarized sunglasses.



### 24/7 Operation

Designed for worry-free round-the-clock operation.



### TrueColor™ Calibration

Every display is factory calibrated to the D65 CIE color standard to produce a natural looking image.



### Thermal Management

Heat generated by the display is radiated away from high temperature areas.



### Automatic Brightness Control

A light sensor measures the ambient light in the area and automatically adjusts the image accordingly.



### Brightness & Color Guaranteed

Guaranteed color and brightness degradation of no more than 9% over 5 years of continuous use.