

MX30

LED Display Controller



Specifications

Change History

| Document Version | Release Date | Description |
|------------------|--------------|---|
| V1.5.1 | 2026-04-30 | <ul style="list-style-type: none">• Added the noise level.• Deleted the Color Replacement feature.• Updated the load capacity loss description. |
| V1.5.0 | 2025-09-30 | <ul style="list-style-type: none">• HDMI 2.0 input supports YCbCr 4:2:0 color sampling format.• Supports central control protocol and viewing of device MAC address.• Supports SPDIF audio output. |
| V1.4.0 | 2024-06-13 | <ul style="list-style-type: none">• The Layer Setting in the LCD interface of the device has been renamed to Layer Parameters. Now, it only shows the parameters without allowing any modifications.• Added information for supported receiving card models. |

Introduction

The MX30 is an all-in-one LED display controller in the brand-new control system COEX series of Xi'an NovaStar Tech Co., Ltd. (hereinafter referred to as NovaStar). This controller integrates video processing and video control into one box and offers rich video input connectors (HDMI 2.0, HDMI 1.4, DP 1.1 and 3G-SDI), 10x Ethernet output ports and 2x 10G optical ports. It can also work with the brand-new software VMP (Vision Management Platform) to provide a better operation and control experience.

Certifications

CE, RoHs, FCC, IC, UL, CB, PSE

If the product does not have the relevant certifications required by the countries or regions where it is to be sold, please contact NovaStar to confirm or address the problem.

Otherwise, the customer shall be responsible for the legal risks caused or NovaStar has the right to claim compensation.

Features

Inputs and Outputs

- Multiple types of inputs
 - 1x HDMI 2.0 (with loop through)
 - 1x HDMI 1.4 (with loop through)
 - 1x DP 1.1
 - 2x 3G-SDI (with loop through)
- 10-bit and 8-bit video inputs
- 3 types of outputs
 - 10x Gigabit Ethernet ports, load capacity up to 6.5 million pixels
 - 2x 10G optical ports
 - 1x SPDIF digital audio port
- 3 types of controls
 - 1x Genlock signal input (with loop through)
 - 2x Ethernet control ports
 - 1x Auxiliary port

Advanced Features

- 3 Independent Layers

Support up to 3 layers and layer priority adjustment in Z order.
- Image Scaling

Each layer supports 4 scaling mode: custom, pixel to pixel, snap to canvas, and fill screen.
- 14Ch Color Correction

Supports precise adjustment to the hue, saturation, and brightness of black and white, and the 12 standard colors derived from the three primary colors (RGB).
- HDR
 - Support HDR10 and comply with the SMPTE ST 2084 and SMPTE ST 2086 standards.
 - Support HLG.

- Full-Grayscale Calibration

Work with NovaStar's high-precision calibration system CC3 along with the scientific-grade cameras CC60 and C3200 to generate unique calibration coefficients for each grayscale, ensuring uniformity of each grayscale and dramatically improving the image quality.

- Latency

- Different screens can have different latency settings. The minimum processing latency of the LED display controller is reduced to 0-frame (less than 1 ms), achieving low latency without reducing the load.
- Supports additional latency. Users can choose to add zero to two frames of latency.

- Preset

For optimal display in various scenarios, users can adjust display parameters such as layers, brightness, color temperature, and gamma ahead of time and save them as presets. Users can save up to 128 customizable presets which can be easily applied or switched with just one click.

- No rectangle restriction

No rectangle restriction for irregular screens. This means when calculating resolutions, blank pixels do not count towards the total capacity. The used load capacity of Ethernet ports is the sum of the resolutions of all cabinets with load.

- Frame Rate Adaptive

Automatically adapt to video inputs with different frame rates ranging from 23.98 Hz to 480 Hz, and support the automatic calculation of optimal screen parameters based on the input source's frame rate. This ensures that the brightness deviation of the screen remains within 5% across different frame rates. It also supports precise frame rate adjustment in 0.01 Hz increments.

- Two working modes

Support the All-In-One Controller and Send-Only Controller working modes.

- In the Send-Only Controller mode, the latency can be reduced by one frame.
- In the All-In-One Controller mode, the layer and scaling functions are available.

Device Controls

- VMP software control

The device can be connected to the VMP software to provide easy and convenient operations and smart device management.

- Supports the SNMP, Art-Net, and central control protocols.
- Cascading control via Ethernet

The Gigabit Ethernet control ports support TCP/IP protocol and star topology. No switch or router is needed to deploy multiple devices on the same LAN via device cascading as the network switching function is already built in.

- Automated system monitoring and alarm

Hardware monitoring capabilities that encompass fan speed, module temperatures, voltage levels, and operational status. It automatically detects and reports any device faults or alarm information, ensuring real-time monitoring of the LED screen's operational status.

Table 4-1 Function Limitations

| Function | Limitation |
|----------------------------|--|
| Frame Rate Adaptive | To use this function, it is required to pair with the A10s Pro and its derivative receiving cards and specific driver ICs (for detailed IC models, please see the product specifications on the NovaStar website at https://www.novastar.tech/). Additionally, you must use the Cabinet Tool provided by NovaStar to adjust the driver IC parameters for different frame rates, which will generate the required NCP file. |
| Full Grayscale Calibration | It is required to work with the A10s Pro\A8s Pro receiving card or their derivatives. Users need to use a CC60\C3200 camera to perform full-grayscale calibration. |
| Calibration Software | COEX V1.5.0 and later versions no longer support the Calcube2.X. Please use the official version of the CC3 calibration software for calibration. |
| Low Latency | Low Latency cannot be enabled simultaneously with Genlock. Moreover, it is recommended to ensure all Ethernet ports load the cabinets vertically and share the same Y coordinate (all set to 0) when Low Latency is enabled. |
| HDR | Enabling the HDR function does not reduce the MX30 load capacity by half if the MX30 works with the A10s Pro\A8s Pro receiving card and its derivative series. For details, please refer to Ethernet Port Load Capacity . |

Table 4-2 Supported receiving card models

| Receiving Card Model | Supported |
|-------------------------|-----------|
| A10s Pro and its series | Yes |
| A8s Pro and its series | Yes |
| A8s and its series | Yes |
| A8s-N | Yes |

| Receiving Card Model | Supported |
|----------------------|-----------|
| A7s Plus | Yes |
| A5s Plus | Yes |
| B6s | Yes |

Appearance

Front Panel

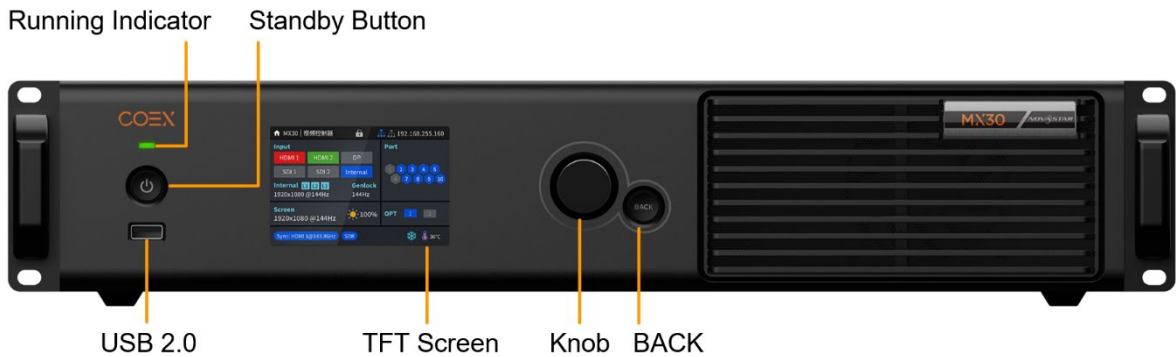

| Name | Function |
|-------------------|--|
| Running indicator | <ul style="list-style-type: none"> • Solid red: Standby. • Solid blue: The device is being powered on. • Solid green: The device is running normally. • Flashing red: The device is running abnormally. |
| Standby button | <ul style="list-style-type: none"> • Press the button to power on or power off the device. • Hold down the button for 5s to 10s to restart the device. |
| USB 2.0 | <ul style="list-style-type: none"> • Connect to a USB drive only to export the device diagnostic result. • Only the NTFS and FAT32 file systems are supported. Others are not supported. |
| TFT Screen | A 3.5-inch screen to display the device status, menus, submenus and messages for parameter settings. |
| Knob | <ul style="list-style-type: none"> • On the home screen, press the knob to enter the main menu screen. • On the main menu screen, rotate the knob to select a menu item or adjust the parameter value. Press the knob to confirm the operation. • Hold down the knob and BACK button simultaneously for 5s or longer to lock or unlock the buttons and screen. |
| BACK | Go back to the previous menu or cancel the current operation. |

Rear Panel



| Inputs | | | |
|------------------|-----|---------------------------|--|
| Type | Qty | Description | |
| HDMI 2.0-1 IN | 1 | Resolutions | Max resolution: 4096×2160@60Hz/8192×1080@60Hz (Forced) Min resolution: 800×600@60Hz |
| | | Max width/height (Forced) | Max width: 8192 pixels (8192×1080@60Hz) Max height: 7680 pixels (1080×7680@60Hz) |
| | | Frame rates | 23.98/24/25/29.97/30/47.95/48/50/59.94/60/71.93/72/75 /100/119.88/120/143.86/144/240 Hz |
| | | HDR | Support HDR10 and comply with the SMPTE ST 2084 and SMPTE ST 2086 standards. Support HLG. |
| | | EDID management | Support standard resolutions, up to 3840×2160@60Hz. Support custom input resolutions. |
| | | HDCP | HDCP 2.2 compliant, backwards compatible with HDCP 1.4/HDCP 1.3. |
| | | Interlaced signal inputs | Not supported. |
| HDMI 1.4-2 IN | 1 | Resolutions | Max resolution: 4096×1080@60Hz Min resolution: 800×600@60Hz |
| | | Max width/height (Forced) | Max width: 4096 pixels (4096×1080@60Hz) Max height: 4096 pixels (1080×4096@60Hz) |
| | | Frame rates | 23.98/24/25/29.97/30/47.95/48/50/59.94/60/71.93/72/75 /100/119.88/120/143.86/144/240 Hz |
| | | EDID management | Support standard resolutions, up to 3840×1080@60Hz. |

| | | | |
|-----------|-----|--|---|
| | | | Support custom input resolutions. |
| | | HDCP | HDCP 2.2 compliant, backwards compatible with HDCP 1.4/HDCP 1.3. |
| | | Interlaced signal inputs | Not supported. |
| DP 1.1 | 1 | Resolutions | Max resolution: 4096×1080@60Hz Min resolution: 800×600@60Hz |
| | | Max width/height (Forced) | Max width: 4096 pixels (4096×1080@60Hz) Max height: 4096 pixels (1080×4096@60Hz) |
| | | Frame rates | 23.98/24/25/29.97/30/47.95/48/50/59.94/60/71.93/72/75 /100/119.88/120/143.86/144/240 Hz |
| | | EDID management | Support standard resolutions, up to 3840×1080@60Hz. Support custom input resolutions. |
| | | HDCP | HDCP 1.3 compliant. |
| | | Interlaced signal inputs | Not supported. |
| 3G-SDI IN | 2 | Standards | Support ST-424 (3G) and ST-292 (HD) standard video inputs. Support 3G-Level A. |
| | | Resolutions | Max resolution: 1920×1080@60Hz |
| | | Frame rates | 23.98/24/25/29.97/30/47.95/48/50/59.94/60 Hz |
| | | Interlaced signal inputs | Support MQ level deinterlacing. The interlaced signals will be automatically detected and converted to progressive signals. |
| Outputs | | | |
| Type | Qty | Description | |
| 1-10 | 10 | Gigabit Ethernet output ports. Support hot backup between Ethernet ports. <ul style="list-style-type: none"> • Max device load capacity: 6.5 million pixels • Max output width/height: 16,384 pixels • The maximum load capacity per Ethernet port is as follows. For details, please refer to Ethernet Port Load Capacity. <ul style="list-style-type: none"> – 8bit@60Hz: 659,722 pixels – 10bit@60Hz: 329,861 pixels (when working with the A10s Pro or A8s Pro receiving cards, the load capacity is 494,791 pixels) | |

| OPT 1-2 | 2 | <p>10G optical output ports with a transmission rate of 10.3125 Gbps.</p> <ul style="list-style-type: none"> • OPT 1 transmits the data of Ethernet ports 1 to 10. • OPT 2 is the copy channel of OPT 1. <p> Note</p> <p>The product doesn't include an optical module by default. If you need one, it's recommended to choose a compatible NovaStar product.</p> |
|--------------------|-----|---|
| HDMI 2.0-1 LOOP | 1 | HDMI loop through. Up to 8 devices can be cabled in one loop. |
| HDMI 1.4-2 LOOP | 1 | |
| 3G-SDI LOOP | 2 | SDI loop through. Up to 8 devices can be cabled in one loop. |
| SPDIF OUT | 1 | Digital audio output connector allows for selecting one of the input sources from the HDMI 2.0, HDMI 1.4, or DP 1.1 as the audio output. |
| Controls | | |
| Type | Qty | Description |
| ETHERNET | 2 | <p>Gigabit Ethernet control ports. Support TCP/IP protocol and star connection.</p> <p>They have the same functions without priority and order, and can be connected to VMP software and central control devices. No switch or router is needed to deploy multiple devices on the same LAN via device cascading as the network switching function is already built in. Up to 20 MX30 can be cascaded.</p> |
| GENLOCK | 1 | <p>A pair of Genlock signal connectors. Support Bi-Level, Tri-Level, and Blackburst.</p> <ul style="list-style-type: none"> • IN: Accept the sync signal • LOOP: Loop the sync signal <p>The Genlock input signal supports a frame rate range from 23.98 Hz to 60 Hz. For standard Genlock signal generators, up to 20 MX30 can be cascaded.</p> |
| AUX | 1 | An auxiliary connector for connecting to central control devices (RS232). |
| Power | | |
| 100-240V~, 50/60Hz | 1 | An AC power input connector and switch |

Note

The maximum input resolution and maximum width and height of HDMI and DP connectors must be obtained by setting the graphics card.

Dimensions

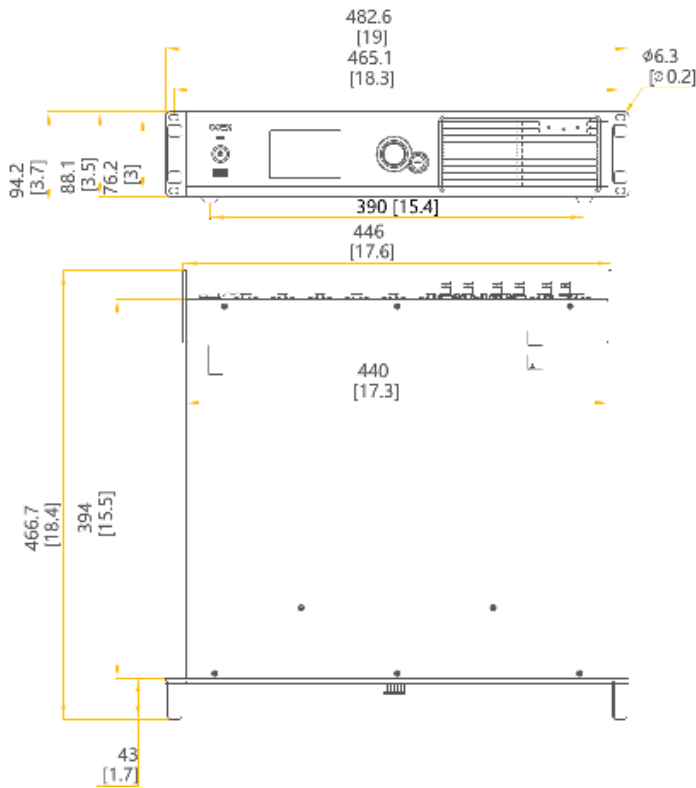

Tolerance: ± 0.3 [± 0.012] Unit: mm [inch]

Product Specifications

| | | |
|---------------------------|-----------------------|--|
| Electrical Specifications | Power input | 100-240V~, 50/60Hz |
| | Max power consumption | 55 W |
| Operating Environment | Temperature | -20°C to +45°C |
| | Humidity | 0% RH to 80% RH, non-condensing |
| Storage Environment | Temperature | -30°C to +80°C |
| | Humidity | 0% RH to 95% RH, non-condensing |
| Physical Specifications | Dimensions | 482.6 mm × 94.2 mm × 466.7 mm (foot pad included) |
| | Net weight | 7.2 kg |
| | Gross weight | 10.2 kg Note: It is the total weight of the product, accessories, and packing materials packed according to the packing specifications. |

| | | |
|------------------------------------|---------------|--|
| Packing Information | Packing box | 595.0 mm × 575.0 mm × 215.0 mm, kraft paper box |
| | Accessory box | 408.0 mm × 294.0 mm × 51.0 mm, white cardboard box |
| | Accessories | <ul style="list-style-type: none"> • 1x Power cord • 1x Ethernet cable • 1x HDMI cable • 1x DP cable • 1x Certificate of Approval |
| IP Rating | | IP20 (Please prevent the product from water intrusion and do not wet or wash the product). |
| Noise Level (typical at 25°C/77°F) | | 41.2 dB (A) |

The amount of power consumption may vary depending on various factors such as product settings, usage, and environment.

Video Source Specifications

| Input | Resolution | | Color Space | Sampling | Bit Depth | Integer Frame Rate (Hz) | |
|-----------|------------|--------------------|-------------|----------|-----------|---|------------------------------|
| HDMI 2.0 | 4K | 4096×2160 (Forced) | RGB / YCbCr | 4:4:4 | 10bit | 24/25/30/48/50 | |
| | | | | | 8bit | 24/25/30/48/50/60 | |
| | | | YCbCr | 4:2:2 | 8/10bit | 30/48/50/60 | |
| | | | | 4:2:0 | 8/10bit | | |
| | 3840×2160 | RGB / YCbCr | 4:4:4 | 4:4:4 | 10bit | 24/25/30/48/50 | |
| | | | | | 8bit | 24/25/30/48/50/60 | |
| | | YCbCr | 4:2:2 | 4:2:2 | 8/10bit | 48/50/60 | |
| | | | | | 4:2:0 | | 8/10bit |
| | 2K1K | 2560×1440 | RGB / YCbCr | 4:4:4 | 4:4:4 | 10bit | 24/25/30/48/50/60/75/100 |
| | | | | | | 8bit | 24/25/30/48/50/60/75/100/120 |
| | | | YCbCr | 4:2:2 | 4:2:2 | 8/10bit | 75/100/120 |
| | | | | | | 4:2:0 | |
| 1920×1080 | | RGB / YCbCr | 4:4:4 | 4:4:4 | 10bit | 24/25/30/48/50/60/72/75/100/120/144 | |
| | | | | | 8bit | 24/25/30/48/50/60/72/75/100/120/144/240 | |
| | | YCbCr | 4:2:2 | 4:2:2 | 8/10bit | | |
| | | | | | 4:2:0 | | 8/10bit |

| Input | Resolution | | Color Space | Sampling | Bit Depth | Integer Frame Rate (Hz) | |
|----------|------------|--------------------|-------------|----------|---------------------------------|-------------------------------------|----------------------|
| | | | | 4:2:0 | 8/10bit | 120/144/240 | |
| HDMI 1.4 | 4K | 4096×2160 (Forced) | RGB / YCbCr | 4:4:4 | 10bit | 24/25 | |
| | | | | | 8bit | 24/25/30 | |
| | | | YCbCr | 4:2:2 | 8/10bit | | |
| | | 3840×2160 | RGB / YCbCr | 4:4:4 | 10bit | 24/25/30 | |
| | | | | | 8bit | | |
| | | | YCbCr | 4:2:2 | 8/10bit | | |
| | 2K1K | 2560×1440 | RGB / YCbCr | 4:4:4 | 10bit | 24/25/30/48/50/60 | |
| | | | | | 8bit | | 24/25/30/48/50/60/75 |
| | | | | | YCbCr | | |
| | | 1920×1080 | RGB / YCbCr | 4:4:4 | 10bit | 24/25/30/48/50/60/72/75/100 | |
| 8bit | | | | | 24/25/30/48/50/60/72/75/100/120 | | |
| YCbCr | | | 4:2:2 | 8/10bit | | | |
| DP 1.1 | 4K | 4096×2160 (Forced) | RGB / YCbCr | 4:4:4 | 10bit | 24/25/30 | |
| | | | | | 8bit | | |
| | | | YCbCr | 4:2:2 | 8/10bit | | |
| | | 3840×2160 | RGB / YCbCr | 4:4:4 | 10bit | 24/25/30 | |
| | | | | | 8bit | | |
| | | | YCbCr | 4:2:2 | 8/10bit | | |
| | 2K1K | 2560×1440 | RGB / YCbCr | 4:4:4 | 10bit | 24/25/30/48/50/60 | |
| | | | | | 8bit | | 24/25/30/48/50/60/75 |
| | | | | | YCbCr | | |
| | | 1920×1080 | RGB / YCbCr | 4:4:4 | 10bit | 24/25/30/48/50/60/72/75/100/120 | |
| | | | | | 8bit | 24/25/30/48/50/60/72/75/100/120/144 | |
| | | | YCbCr | 4:2:2 | 8/10bit | | |
| 3G-SDI | 2K1K | 2048×1080 | YCbCr | 4:2:2 | 10bit | 24/25/30/48/50/60 | |
| | | 1920×1080 | | | | | |

Note

- The table above only displays a selection of common resolutions and integer frame rates. Decimal frame rates are also supported, allowing for automatic frame rate adaptation from the highest frame rate of each resolution down to 23.98/29.97/47.95/59.94/71.93/119.88/143.86 Hz.
- When using YCbCr 4:2:0 input, all frame rates need to be forced. Standard graphics cards only support a 4K resolution at 50/60 Hz. Other resolutions and frame rates require a source device that supports this color space and sampling to be forced.

Ethernet Port Load Capacity

When Working with A10s Pro\A8s Pro and Their Derivative Receiving Cards

When working with the A10s Pro\A8s Pro and their derivative receiving cards, the formula of calculating the load capacity per Ethernet port and the detailed parameters are as follows.

- 8bit: Load capacity $\times 24 \times$ Frame rate $< 1000 \times 1000 \times 1000 \times 0.95$
- 10bit: Load capacity $\times 32 \times$ Frame rate $< 1000 \times 1000 \times 1000 \times 0.95$

| Max Load Capacity per Ethernet Port (Pixels) | | |
|--|-----------|-----------|
| Frame Rate / Bit Depth | 8bit | 10bit |
| 24 Hz | 1,649,306 | 1,236,979 |
| 25 Hz | 1,583,333 | 1,187,500 |
| 30 Hz | 1,319,444 | 989,583 |
| 50 Hz | 791,667 | 593,750 |
| 60 Hz | 659,722 | 494,792 |
| 120 Hz | 329,861 | 247,396 |
| 144 Hz | 274,884 | 206,163 |
| 240 Hz | 164,931 | 123,698 |

When Working with Other Armor Series Receiving Cards

When working with other Armor series receiving cards, the formula of calculating the load capacity per Ethernet port and the detailed parameters are as follows:

- 8bit: Load capacity × 24 × Frame rate < 1000 × 1000 × 1000 × 0.95
- 10bit: Load capacity × 48 × Frame rate < 1000 × 1000 × 1000 × 0.95

| Max Load Capacity per Ethernet Port (Pixels) | | |
|--|-----------|---------|
| Frame Rate / Bit Depth | 8bit | 10bit |
| 24 Hz | 1,649,306 | 824,653 |
| 25 Hz | 1,583,333 | 791,667 |
| 30 Hz | 1,319,444 | 659,722 |
| 50 Hz | 791,667 | 395,833 |
| 60 Hz | 659,722 | 329,861 |
| 120 Hz | 329,861 | 164,931 |
| 144 Hz | 274,884 | 137,442 |
| 240 Hz | 164,931 | 82,465 |

Note

- To achieve the maximum load capacity, the width of each rectangular load area within a single Ethernet port must be at least 128 pixels. If the width of a rectangular load area within the Ethernet port is less than 128, the loss in capacity is calculated as (128 - width of the rectangular load area) × height of the rectangular load area. The total load capacity loss for the Ethernet port is the sum of the losses for all rectangular load areas within the port.
- When using the Ethernet port, pair it with a CAT5E cable for a maximum length of 100 meters.

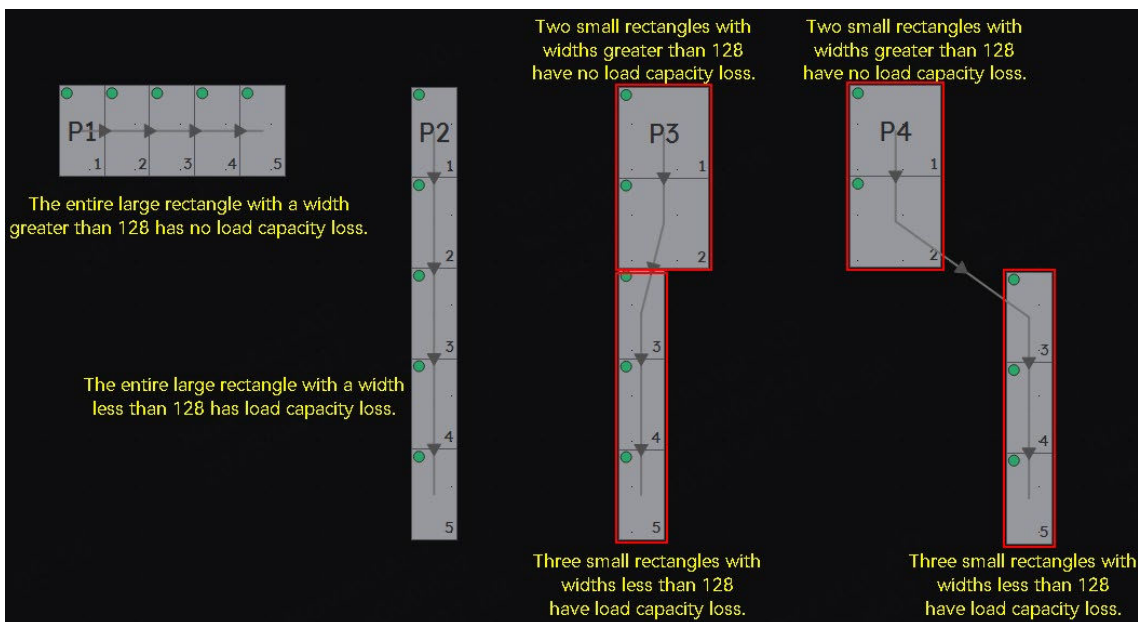

Notes and Cautions

Notes for Battery

- The battery is not intended to be replaced.
- Disposal of a battery into fire or a hot oven, or mechanically crushing or cutting of a battery can result in an explosion.
- Leaving a battery in an extremely high temperature surrounding environment can result in an explosion or the leakage of flammable liquid or gas.
- A battery subjected to extremely low air pressure may result in an explosion or the leakage of flammable liquid or gas.

Notes for Installation

When the product needs to be installed on the rack, 4 screws at least M5*12 should be used to fix it. The rack for installation shall bear at least 9kg weight.

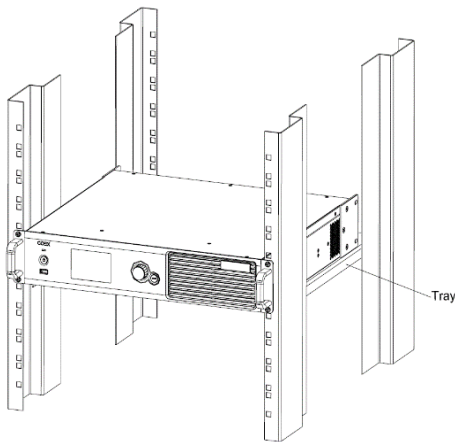

- Elevated Operating Ambient - If installed in a closed or multi-unit rack assembly, the operating ambient temperature of the rack environment may be greater than room ambient. Therefore, consideration should be given to installing the equipment in an environment compatible with the maximum ambient temperature (T_{ma}) specified by the manufacturer.
- Reduced Air Flow - Installation of the equipment in a rack should be such that the amount of air flow required for safe operation of the equipment is not compromised.
- Mechanical Loading - Mounting of the equipment in the rack should be such that a hazardous condition is not achieved due to uneven mechanical loading.

- Circuit Overloading – Consideration should be given to the connection of the equipment to the supply circuit and the effect that overloading of the circuits might have on overcurrent protection and supply wiring. Appropriate consideration of equipment nameplate ratings should be used when addressing this concern.
- Reliable Earthing – Reliable earthing of rack-mounted equipment should be maintained. Particular attention should be given to supply connections other than direct connections to the branch circuit (e.g. use of power strips).

FCC Caution

- Any changes or modifications not expressly approved by the party responsible for compliance could void the user's authority to operate the equipment.
- This device complies with part 15 of the FCC Rules. Operation is subject to the following two conditions: (1) This device may not cause harmful interference, and (2) this device must accept any interference received, including interference that may cause undesired operation.
- Note: This equipment has been tested and found to comply with the limits for a Class A digital device, pursuant to part 15 of the FCC Rules. These limits are designed to provide reasonable protection against harmful interference when the equipment is operated in a commercial environment. This equipment generates, uses, and can radiate radio frequency energy and, if not installed and used in accordance with the instruction manual, may cause harmful interference to radio communications. Operation of this equipment in a residential area is likely to cause harmful interference in which case the user will be required to correct the interference at his own expense.

Others

- This product can only be placed horizontally. Do not mount vertically or upside-down.
- This is Class A product. In a domestic environment, this product may cause radio interference in which case the user may be required to take adequate measures.

Copyright

Copyright © 2026 Xi'an NovaStar Tech Co., Ltd. All Rights Reserved.

No part of this document may be copied, reproduced, extracted or transmitted in any form or by any means without the prior written consent of Xi'an NovaStar Tech Co., Ltd.

Trademark

 is a trademark of Xi'an NovaStar Tech Co., Ltd.

Statement

Thank you for choosing NovaStar's product. This document is intended to help you understand and use the product. For accuracy and reliability, NovaStar may make improvements and/or changes to this document at any time and without notice. If you experience any problems in use or have any suggestions, please contact us via the contact information given in this document. We will do our best to solve any issues, as well as evaluate and implement any suggestions.

| Official website
| www.novastar.tech

| Technical support
| support@novastar.tech